

## Garter-Spring Radial Lip Seal with Molded Case

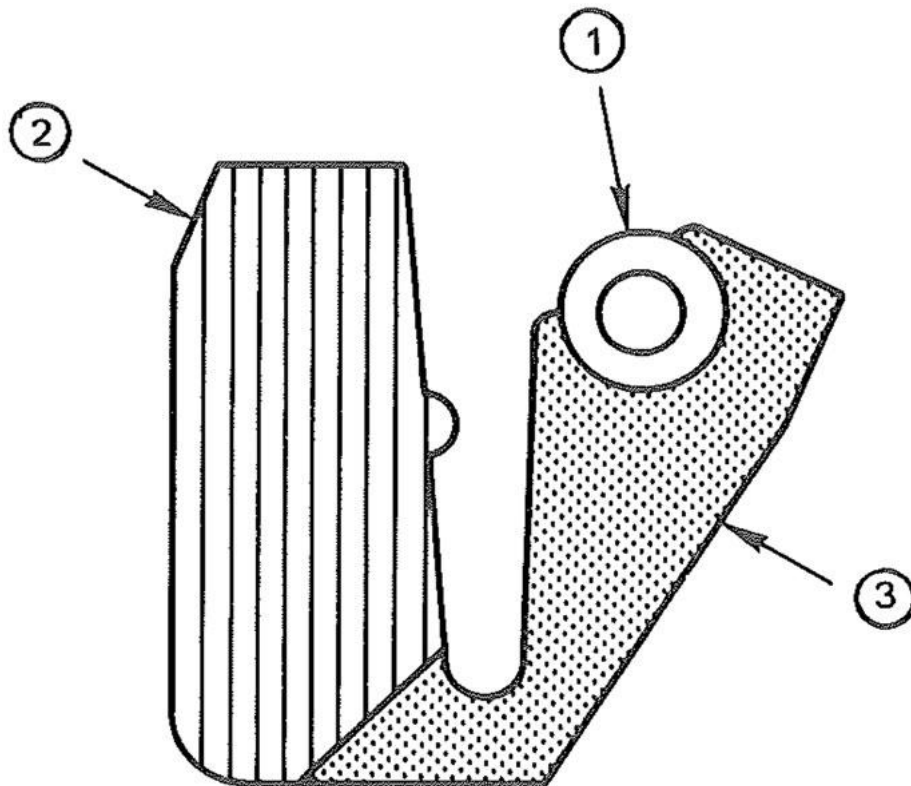

1. Garter Spring
2. Molded Case
3. Sealing Element

**1. Garter Spring:** A helically coiled wire spring with its ends connected. It is used in tension for maintaining a radial sealing force between the sealing element of a radial lip seal and a shaft.

**2. Molded Case:** A design feature of a type of radial lip seal wherein the lip and case are made integral in the molding process.

**3. Sealing Element:** The normally flexible elastomeric component of a lip seal assembly, which rides against the rotating surface and effects the seal.